

PRODUCT SPECIFICATION SHEET

PART: G102-012

FASTENER SYSTEM WORKS WITH ALL GYPSUM WALLBOARD TOWEL BAR MODELS
 FASTENER SYSTEM ONLY WORKS WITH WOOD BLOCKING (DO NOT USE WALL ANCHORS)
 REFER TO INSTALLATION INSTRUCTIONS BEFORE USE

PROMESSA™ SERIES

18" TOWEL BAR (TRADITIONAL) KIT

[GYPSUM WALLBOARD INSTALLATION SYSTEMS]

FINISHES: PC, BN, ORB

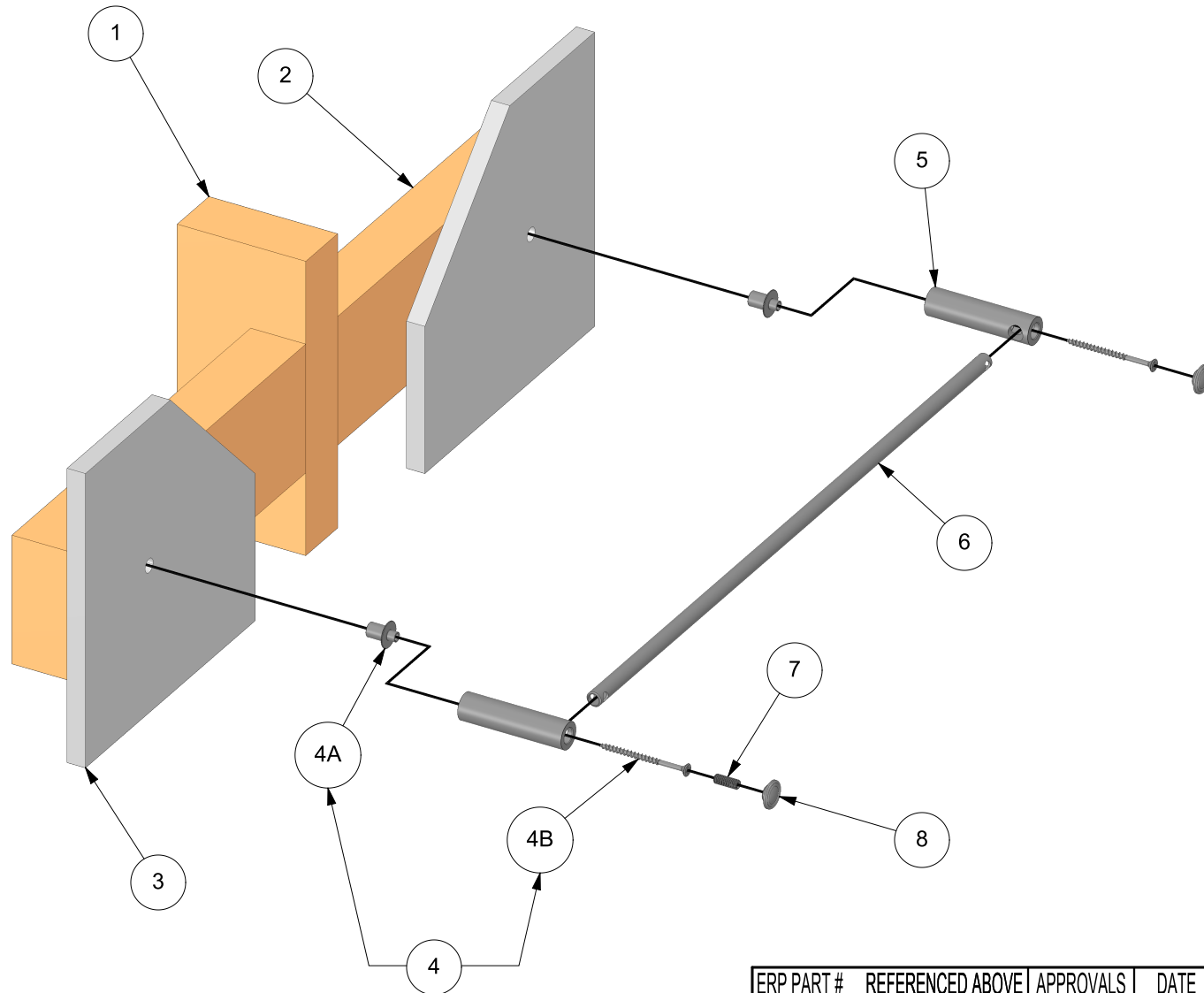

TW-ENG5



TileWare Products
 www.tilewareproducts.com

ERP PART #	REFERENCED ABOVE	APPROVALS	DATE
DWG #	583B	RLS	6/10/16
SHEET 1 OF 3	SCALE 1:4		
WEIGHT:	0.832 LB	CUBED:	2.850 IN ³

Office (828) 322-9273 Fax (828) 304-1076

PRODUCT SPECIFICATION SHEET

PART: G102-012

FASTENER SYSTEM WORKS WITH ALL GYPSUM WALLBOARD TOWEL BAR MODELS
 FASTENER SYSTEM ONLY WORKS WITH WOOD BLOCKING (DO NOT USE WALL ANCHORS)
 REFER TO INSTALLATION INSTRUCTIONS BEFORE USE

PROMESSA™ SERIES

18" TOWEL BAR (TRADITIONAL) KIT

[GYPSUM WALLBOARD INSTALLATION SYSTEMS]

FINISHES: PC, BN, ORB

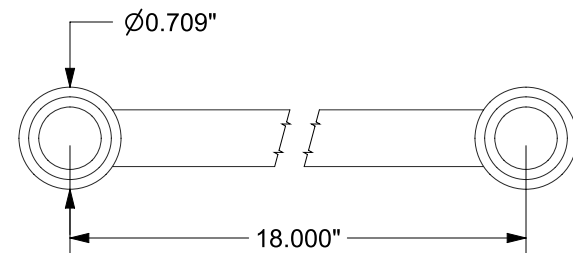
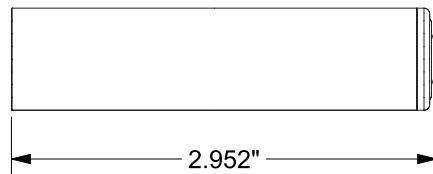
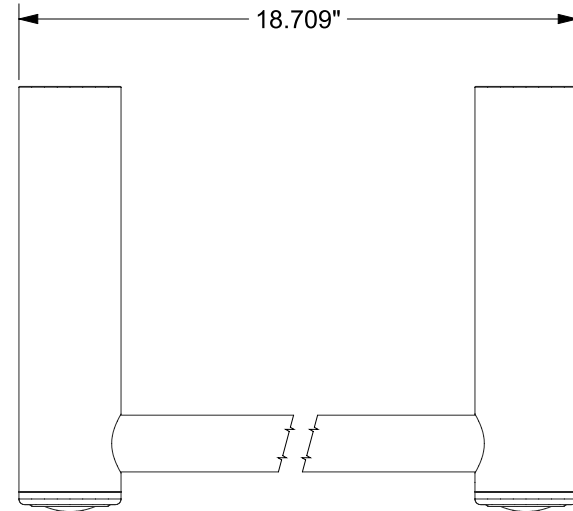
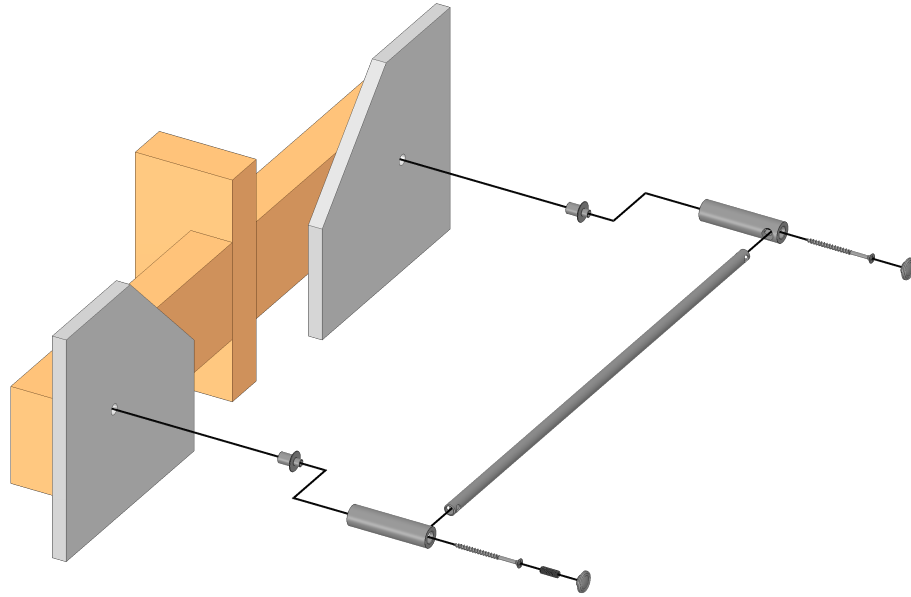

ERP PART #	REFERENCED ABOVE	APPROVALS	DATE
DWG #	583B	RLS	6/10/16
SHEET 2 OF 3	SCALE 3:4		
WEIGHT:	0.832 LB	CUBED:	2.850 IN ³

TW-ENG5



TileWare Products

www.tilewareproducts.com

Office (828) 322-9273 Fax (828) 304-1076

PRODUCT SPECIFICATION SHEET

PART: G102-012







FASTENER SYSTEM WORKS WITH ALL GYPSUM WALLBOARD TOWEL BAR MODELS
 FASTENER SYSTEM ONLY WORKS WITH WOOD BLOCKING (DO NOT USE WALL ANCHORS)
 REFER TO INSTALLATION INSTRUCTIONS BEFORE USE

PROMESSA™ SERIES

18" TOWEL BAR (TRADITIONAL) KIT

[GYPSUM WALLBOARD INSTALLATION SYSTEMS]

FINISHES: PC, BN, ORB

MODEL IMAGE	REF #	PART #	DESCRIPTION	MATERIAL	QTY	MODEL IMAGE	REF #	PART #	DESCRIPTION	MATERIAL	QTY
	1		STUD WALL PARTITION	WOOD			5	C220-001	TOWEL BAR SLEEVE	BRASS	2
	2		STUD WALL BLOCKING	WOOD			6	C220-007	TOWEL ROD	BRASS	1
	3		WALLBOARD PANEL	GYPSUM PANEL			7	C100-005	TOWEL BAR CAP SET SCREW (FOR ANTI - ROTATION, LEFT CAP ONLY)	STAINLESS STEEL	1
	4	PG100-508	TOWEL BAR GYPSUM WALLBOARD FASTENER	ASSEMBLY	1		8	C220-012	TRADITIONAL CAP	BRASS	2
	4A	C200-044	SPACER	ALUMINUM	1						
	4B	C200-041	# 8 X 2 1/2" PHILLIPS FLAT HEAD SCREW	ZINC - PLATED	1						

TW-ENG5



TileWare Products
 www.tilewareproducts.com

Office (828) 322-9273 Fax (828) 304-1076

ERP PART #	REFERENCED ABOVE	APPROVALS	DATE
DWG #	583B	RLS	6/10/16
SHEET 3 OF 3	SCALE N/A		
WEIGHT:	0.832 LB	CUBED:	2.850 IN ³